

KS Magnetscheibenkupplung Magnetic Disk Coupling

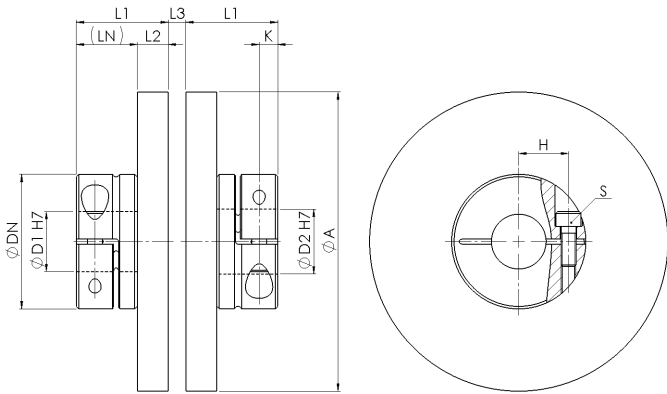

Material:
Stahl
Nabe - Aluminium
Temperaturbereich:
-30 °C bis +120 °C
Optional Passfedernut ØD1 / ØD2:
Nach DIN 6885

Material:
Steel
Hub - aluminum
Temperature range:
-30 °C to +120 °C
Optional keyway ØD1 / ØD2:
Acc. to DIN 6885

KS		Abmessungen Dimensions								ISO 4762	Technische Daten Technical Data			
Größe Size	TKN ¹	L1	ØA	ØD1 / ØD2	ØDN	L2	LN	K	H	S	TA	J	n _{max}	M
	[Nm]	[mm]									[Nm]	[kg cm ²]	[min ⁻¹]	[kg]
2	2,5	29,8	84	8 - 25,4	45	9,3	20,5	5,75	17,5	M5	11	7,5	13500	0,3
10	11	29,8	100	8 - 25,4	45	9,3	20,5	5,75	17,5	M5	11	7,9	11000	0,7
15	17	34	124	10 - 30	54	9,5	24,5	7,5	20	M6	19	10,2	9100	1,2
25	33	34,8	144	10 - 30	54	10,3	24,5	7,5	20	M6	19	10,6	7500	1,6

¹ L3=5mm

Massenträgheitsmoment und Masse sind mit dem größten Bohrungsdurchmesser gerechnet. Mass moment of inertia and mass are calculated with reference to the largest bore size. Laufend aktualisierte Daten finden Sie auf unserer Homepage. For continuously updated data please refer to our website.

Technische Daten	Technical Data
TKN - Drehmoment	TKN - Torque
TA - Anzugs-Drehmoment der Schraube	TA - Installation torque per screw
J - Massenträgheitsmoment	J - Mass moment of inertia
n _{max} - max. Drehzahl	n _{max} - max. speed
M - Masse	M - Mass

Bestellbeispiel / order example	KS	10	20	16	SX
Modell / model					
Größe / size					
Bohrung ØD1 H7 / bore ØD1 H7					
Bohrung ØD2 H7 / bore ØD2 H7					
Sonderoption / special option					

