

# SWK/LB-LP mit Konus-Klemmnabe / Passfederverbindung with conical clamping hub / keyway connection

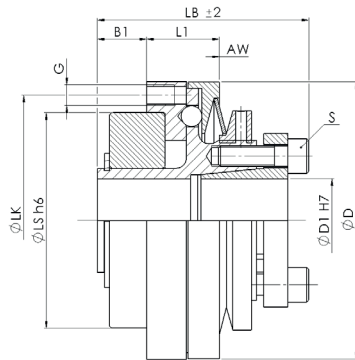

Version LB

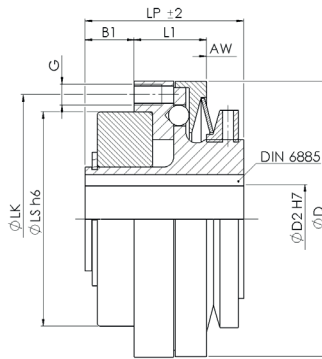

Version LP

**Material:**  
Stahl  
**Temperaturbereich:**  
-30 °C bis +120 °C  
**SWK/LB:**  
Optional Passfedernut nach DIN 6885  
**SWK/LP:**  
Passfedernut nach DIN 6885  
**Schaltart:**  
Synchronausführung  
Optional: Durchrastausführung

**Material:**  
Steel  
**Temperature range:**  
-30 °C to +120 °C  
**SWK/LB:**  
Optional keyway acc. to DIN 6885  
**SWK/LP:**  
Keyway acc. to DIN 6885  
**Winding connection:**  
Synchronous version  
Optional:  
Multi-position re-engagement version

SWK/LB   SWK/LP			Abmessungen Dimensions										ISO 4762	Technische Daten Technical Data				
Größe Size	1 TKN	2 TKN	LB	LP	ØD	ØD1	ØD2	ØLS	ØLK	L1	B1	AW	G	S	TA	J	n <sub>max</sub>	M
	[Nm]		[mm]												[Nm]	[kg cm <sup>2</sup> ]	[min <sup>-1</sup> ]	[kg]
10	1,2 - 3	2,5 - 10	43,5	33,5	59	5 - 16	5 - 12	47	53	14	12	0,8	6x M4	M4	5	1,7	3000	0,4
30	6 - 16	10 - 30	50	38	67	9 - 20	9 - 17	55	61	18	13	1,2	6x M4	M4	5	3,6	3000	0,65
60	10 - 25	20 - 60	61	46	80	12 - 25	12 - 20	62	72	23	14	1,2	6x M6	M6	19	8,5	3000	1,1
100	30 - 75	50 - 100	66	51	103	20 - 42	20 - 45	85	95	27	11	1,8	6x M6	M6	19	19	2500	2,3
200	50 - 130	80 - 200	72	57	103	20 - 42	20 - 35	80	95	27	17	1,8	6x M6	M6	19	28	2500	2,2
300	80 - 170	150 - 300	95	77	140	25 - 46	25 - 50	110	127	34	23,5	1,8	6x M8	M8	42	121	2000	5,5
500	100 - 300	250 - 500	95	77	140	30 - 50	30 - 50	110	127	34	23,5	1,8	6x M8	M8	42	124	2000	5,6

Massenträgheitsmoment und Masse sind mit dem größten Bohrungsdurchmesser gerechnet. Mass moment of inertia and mass are calculated with reference to the largest bore size. Laufend aktualisierte Daten finden Sie auf unserer Homepage. For continuously updated data please refer to our website.

### Technische Daten

TKN - Drehmoment  
AW - Ausrückweg  
TA - Anzugs-Drehmoment der Schraube  
J - Massenträgheitsmoment  
n<sub>max</sub> - max. Drehzahl  
M - Masse

### Technical Data

TKN - Torque  
AW - Disengaging travel  
TA - Installation torque per screw  
J - Mass moment of inertia  
n<sub>max</sub> - max. speed  
M - Mass

### Bestellbeispiel / order example

	SWK/LB	30	14	10Nm	1	SX
Modell / model						
Größe / size						
Bohrung ØD1 H7 / bore ØD1 H7						
Ausrückmoment / disengaging torque						
Drehmomentbereich / torque range						
Sonderoption / special option						

