

SWK/CB-CP mit Konus-Klemmnabe / Passfederverbindung with conical clamping hub / keyway connection

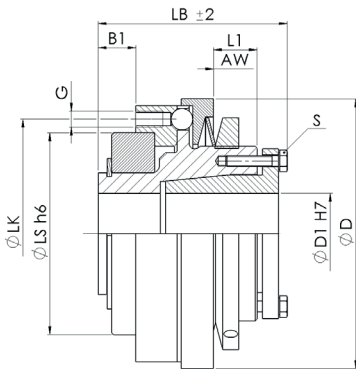

Version CB

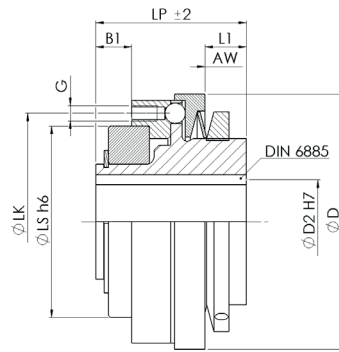

Version CP

Material:
Stahl
Temperaturbereich:
-30 °C bis +120 °C
SWK/CB:
Optional Passfedernut nach DIN 6885
SWK/CP:
Passfedernut nach DIN 6885
Schaltart:
Synchronausführung
Optional: Durchtrastausführung

Material:
Steel
Temperature range:
-30 °C to +120 °C
SWK/CB:
Optional keyway acc. to DIN 6885
SWK/CP:
Keyway acc. to DIN 6885
Winding connection:
Synchronous version
Optional:
Multi-position re-engagement version

SWK/CB SWK/CP					Abmessungen Dimensions												ISO 4017	Technische Daten Technical Data				
Größe Size	1 TKN	2 TKN	3 TKN	4 TKN	LB	LP	ØD	ØD1	ØD2	ØL	ØLK	B1	L1	AW	G	S	TA	J	η _{max}	M (CB)	M (CP)	
	[Nm]				[mm]												[Nm]	[kg cm ²]	[min ⁻¹]	[kg]		
30	5 - 12,5	10 - 25	20 - 50	25 - 62,5	50	40	70	10 - 20	10 - 20	47	56	8	12	1,2	8x M4	6x M4	4,5	1,1	4000	0,7	0,7	
60	10 - 25	20 - 50	40 - 100	50 - 125	59	48	85	15 - 25	15 - 25	62	71	11	13,5	1,2	8x M5	6x M4	4,5	7,5	3000	1,2	1	
200	20 - 50	40 - 100	80 - 200	100 - 250	70	59	100	22 - 35	22 - 30	75	85	14	16	1,8	8x M6	8x M4	4,5	19,5	2500	2	1,8	
300	40 - 100	80 - 200	160 - 400	200 - 500	77	64	115	32 - 45	32 - 40	90	100	16	17	1,8	8x M6	8x M5	9	40	2000	2,9	2,6	
500	70 - 175	140 - 350	280 - 700	350 - 875	90,5	75	135	35 - 55	35 - 50	100	116	18	20,5	1,8	8x M8	8x M6	16	91	1200	4,6	4	
800	120 - 300	240 - 600	480 - 1200	600 - 1500	136	115	166	40 - 65	40 - 65	130	150	21	46	2	8x M10	8x M8	36	357	800	10,7	10	

Massenträgheitsmoment und Masse sind mit dem größten Bohrungsdurchmesser gerechnet. Mass moment of inertia and mass are calculated with reference to the largest bore size. Laufend aktualisierte Daten finden Sie auf unserer Homepage. For continuously updated data please refer to our website.

Technische Daten

TKN - Drehmoment
AW - Ausrückweg
TA - Anzugs-Drehmoment der Schraube
J - Massenträgheitsmoment
η_{max} - max. Drehzahl
M - Masse

Technical Data

TKN - Torque
AW - Disengaging travel
TA - Installation torque per screw
J - Mass moment of inertia
η_{max} - max. speed
M - Mass

Bestellbeispiel / order example	SWK/CB	200	30	60Nm	2	SX
Modell / model						
Größe / size						
Bohrung ØD1 H7 / bore ØD1 H7						
Ausrückmoment / disengaging torque						
Drehmomentbereich / torque range						
Sonderoption / special option						

