

# SWK/BK mit Konus-Klemmnabe - Metallbalgausführung with conical clamping hub - metal bellow version

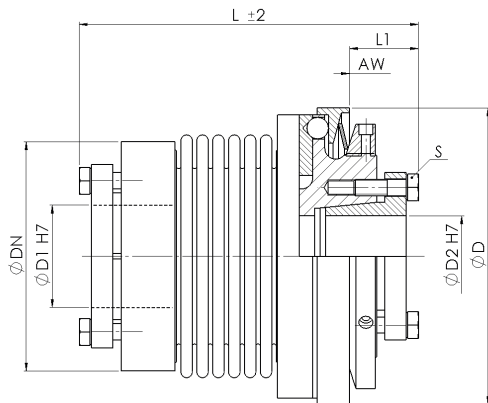

**Material:** Stahl  
Balg - Edelstahl  
Nabe - Aluminium / Stahl  
**Temperaturbereich:**  
-30 °C bis +120 °C  
**Optional Passfedernut ØD1 / ØD2:**  
Nach DIN 6885  
**Schaltart:**  
Synchronausführung  
Optional: Durchrastausführung

**Material:** Steel  
Bellow - stainless steel  
Hub - aluminum / steel  
**Temperature range:**  
-30 °C to +120 °C  
**Optional keyway ØD1 / ØD2:**  
Acc. to DIN 6885  
**Winding connection:**  
Synchronous version  
Optional:  
Multi-position re-engagement version

SWK/BK			Abmessungen Dimensions							ISO 4017	Technische Daten Technical Data			
Größe Size	1 TKN	2 TKN	L	ØD	ØD1	ØD2	ØDN	L1	AW	S	TA	J	n <sub>max</sub>	M
	[Nm]										[mm]			
10	2 - 5	5 - 10	69	50	5 - 14	5 - 14	41	16	0,8	M4	4,5	0,8	11800	0,3
			79											0,32
30	5 - 15	10 - 30	85	65	9 - 20	9 - 20	53	17	1,2	M4	4,5	3,1	9600	0,8
			94											0,85
60	15 - 35	20 - 60	100	80	12 - 25	12 - 25	65	24	1,2	M6	16	7,6	8150	1,5
			110											1,6
80	15 - 40	30 - 80	115	95	20 - 35	15 - 35	80	21	1,8	M6	16	18	6200	2
			127											2,1
150	25 - 75	65 - 150	115	95	20 - 35	15 - 35	80	21	1,8	M6	16	20	6200	2,5
			127											2,7
200	50 - 140	100 - 200	126	110	20 - 42	20 - 40	85	26	1,8	M6	16	32	5800	3,2
			138											3,4
300	70 - 160	150 - 300	135	120	25 - 50	25 - 46	110	30	1,8	M8	36	64	5250	5,5
			148											5,7
500	80 - 250	200 - 500	150	130	30 - 55	30 - 50	122	30	1,8	M8	36	170	4450	7,2
			162											7,5
800	260 - 600	500 - 800	234	170	30 - 70	30 - 60	140	50	2	M16	300	530	3370	19
1300	450 - 900	800 - 1300	234	170	30 - 70	30 - 60	140	50	2	M16	300	550	3370	20
1600	500 - 1000	900 - 1600	250	195	30 - 75	30 - 90	140	55	2	M16	300	600	2950	22

Massenträgheitsmoment und Masse sind mit dem größten Bohrungsdurchmesser gerechnet. Mass moment of inertia and mass are calculated with reference to the largest bore size.  
Weitere technische Daten, siehe Seite 694. Further technical data, see page 69.  
Laufend aktualisierte Daten finden Sie auf unserer Homepage. For continuously updated data please refer to our website.

### Technische Daten

TKN - Drehmoment  
AW - Ausrückweg  
TA - Anzugs-Drehmoment der Schraube  
J - Massenträgheitsmoment  
n<sub>max</sub> - max. Drehzahl  
M - Masse

### Technical Data

TKN - Torque  
AW - Disengaging travel  
TA - Installation torque per screw  
J - Mass moment of inertia  
n<sub>max</sub> - max. speed  
M - Mass

Bestellbeispiel / order example	SWK/BK	80	115	25	28	40Nm	2	SX
Modell / model								
Größe / size								
Länge / length								
Bohrung ØD1 H7 / bore ØD1 H7								
Bohrung ØD2 H7 / bore ØD2 H7								
Ausrückmoment / disengaging torque								
Drehmomentbereich / torque range								
Sonderoption / special option								

