

# SWK/B (BB) 10-1600

Sicherheitskupplung SWK/B (BB)-Serie / mit Synchronschaltung und Innenkonus  
 Safety coupling SWK/B (BB) / with inner conical hub

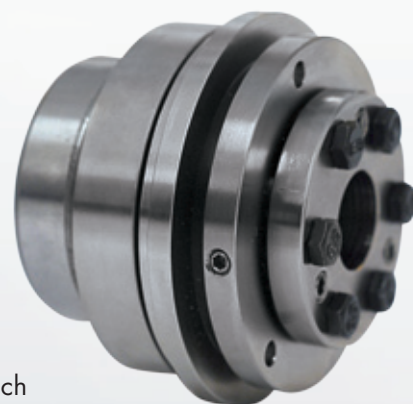
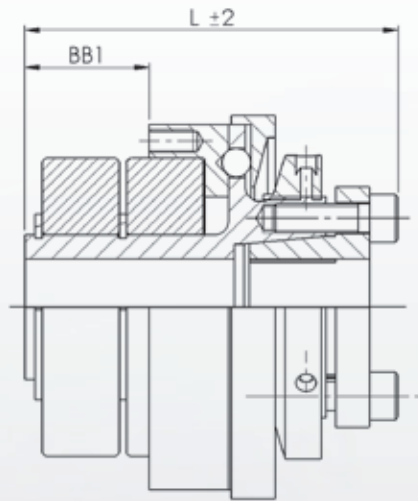
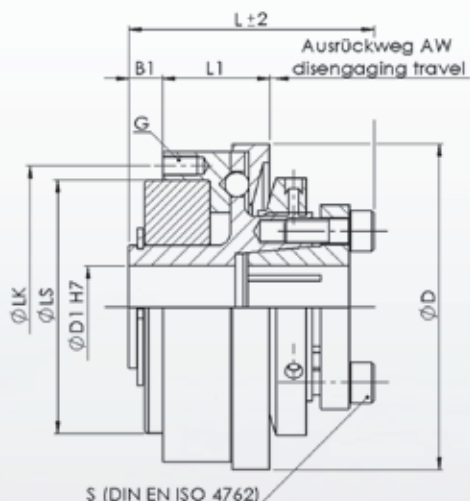

Auch als reine Passfederverbindung erhältlich  
 also available with keyway

Bestellbeispiel  
 Ordering Example

SWK/B-30 - 14 - 10Nm - 1 - SX  
 Typ / Type      ØD1      Ausrückmoment      Drehmomentbereich      Option  
 disengaging torque      torque range

Type	Abmessungen / Dimensions (mm)										Technische Daten																																																																																																																																																																										
SWK/B SWK/BB	ØD	ØD1	ØLS	ØLK	L	L1	B1-BB1	AW	G	S	1 TKN	2 TKN	rpm. (1/min)	kg	J (kg cm <sup>2</sup> )																																																																																																																																																																						
10	49,5	5-16	37	42	36	15	5	0,7	M3	M4/3	2-5	5-10	11800	0,3	1																																																																																																																																																																						
					47		16									30	64,5	9-20	47	53	45	18	6	1,2	M4	M4/5	5-15	10-30	9200	0,45	3	59	19	60	79,5	13-25	62	69	58	25	8	1,2	M5	M6/9	15-35	20-65	7600	0,9	6	75	26	80	94,5	15-35	68	80	60	26	10	2	M6	M6/14	15-40	30-80	6200	1,5	16	76	27	150	94,5	15-35	68	80	60	26	10	2	M6	M6/14	50-130	65-150	5800	1,6	16	76	27	200	109,5	20-40	80	90	66	30	10	2	M6	M6/18	30-90	80-200	5300	2,7	26	86	29	300	119,5	30-42	90	102	74	32	10	2	M8	M8/18	60-200	100-300	4800	3,5	39	95	31	500	129,5	35-50	100	112	74	32	10	2	M8	M8/26	80-250	200-500	4550	4,5	80	95	31	800	169,5	40-60	110	125	110	50	15	2	M12	M16/45	260-600	500-900	3400	12,3	275	132	37	1300	169,5	40-60	110	125	110	50	15	2	M12	M16/80	450-900	800-1300	3400	12,3	275	132	37	1600	194,5	60-90	150
30	64,5	9-20	47	53	45	18	6	1,2	M4	M4/5	5-15	10-30	9200	0,45	3																																																																																																																																																																						
					59		19									60	79,5	13-25	62	69	58	25	8	1,2	M5	M6/9	15-35	20-65	7600	0,9	6	75	26	80	94,5	15-35	68	80	60	26	10	2	M6	M6/14	15-40	30-80	6200	1,5	16	76	27	150	94,5	15-35	68	80	60	26	10	2	M6	M6/14	50-130	65-150	5800	1,6	16	76	27	200	109,5	20-40	80	90	66	30	10	2	M6	M6/18	30-90	80-200	5300	2,7	26	86	29	300	119,5	30-42	90	102	74	32	10	2	M8	M8/18	60-200	100-300	4800	3,5	39	95	31	500	129,5	35-50	100	112	74	32	10	2	M8	M8/26	80-250	200-500	4550	4,5	80	95	31	800	169,5	40-60	110	125	110	50	15	2	M12	M16/45	260-600	500-900	3400	12,3	275	132	37	1300	169,5	40-60	110	125	110	50	15	2	M12	M16/80	450-900	800-1300	3400	12,3	275	132	37	1600	194,5	60-90	150	168	125	60	19	2	M12	M12/90	500-1000	900-1600	3050	16,5	320	152	46				
60	79,5	13-25	62	69	58	25	8	1,2	M5	M6/9	15-35	20-65	7600	0,9	6																																																																																																																																																																						
					75		26									80	94,5	15-35	68	80	60	26	10	2	M6	M6/14	15-40	30-80	6200	1,5	16	76	27	150	94,5	15-35	68	80	60	26	10	2	M6	M6/14	50-130	65-150	5800	1,6	16	76	27	200	109,5	20-40	80	90	66	30	10	2	M6	M6/18	30-90	80-200	5300	2,7	26	86	29	300	119,5	30-42	90	102	74	32	10	2	M8	M8/18	60-200	100-300	4800	3,5	39	95	31	500	129,5	35-50	100	112	74	32	10	2	M8	M8/26	80-250	200-500	4550	4,5	80	95	31	800	169,5	40-60	110	125	110	50	15	2	M12	M16/45	260-600	500-900	3400	12,3	275	132	37	1300	169,5	40-60	110	125	110	50	15	2	M12	M16/80	450-900	800-1300	3400	12,3	275	132	37	1600	194,5	60-90	150	168	125	60	19	2	M12	M12/90	500-1000	900-1600	3050	16,5	320	152	46																						
80	94,5	15-35	68	80	60	26	10	2	M6	M6/14	15-40	30-80	6200	1,5	16																																																																																																																																																																						
					76		27									150	94,5	15-35	68	80	60	26	10	2	M6	M6/14	50-130	65-150	5800	1,6	16	76	27	200	109,5	20-40	80	90	66	30	10	2	M6	M6/18	30-90	80-200	5300	2,7	26	86	29	300	119,5	30-42	90	102	74	32	10	2	M8	M8/18	60-200	100-300	4800	3,5	39	95	31	500	129,5	35-50	100	112	74	32	10	2	M8	M8/26	80-250	200-500	4550	4,5	80	95	31	800	169,5	40-60	110	125	110	50	15	2	M12	M16/45	260-600	500-900	3400	12,3	275	132	37	1300	169,5	40-60	110	125	110	50	15	2	M12	M16/80	450-900	800-1300	3400	12,3	275	132	37	1600	194,5	60-90	150	168	125	60	19	2	M12	M12/90	500-1000	900-1600	3050	16,5	320	152	46																																								
150	94,5	15-35	68	80	60	26	10	2	M6	M6/14	50-130	65-150	5800	1,6	16																																																																																																																																																																						
					76		27									200	109,5	20-40	80	90	66	30	10	2	M6	M6/18	30-90	80-200	5300	2,7	26	86	29	300	119,5	30-42	90	102	74	32	10	2	M8	M8/18	60-200	100-300	4800	3,5	39	95	31	500	129,5	35-50	100	112	74	32	10	2	M8	M8/26	80-250	200-500	4550	4,5	80	95	31	800	169,5	40-60	110	125	110	50	15	2	M12	M16/45	260-600	500-900	3400	12,3	275	132	37	1300	169,5	40-60	110	125	110	50	15	2	M12	M16/80	450-900	800-1300	3400	12,3	275	132	37	1600	194,5	60-90	150	168	125	60	19	2	M12	M12/90	500-1000	900-1600	3050	16,5	320	152	46																																																										
200	109,5	20-40	80	90	66	30	10	2	M6	M6/18	30-90	80-200	5300	2,7	26																																																																																																																																																																						
					86		29									300	119,5	30-42	90	102	74	32	10	2	M8	M8/18	60-200	100-300	4800	3,5	39	95	31	500	129,5	35-50	100	112	74	32	10	2	M8	M8/26	80-250	200-500	4550	4,5	80	95	31	800	169,5	40-60	110	125	110	50	15	2	M12	M16/45	260-600	500-900	3400	12,3	275	132	37	1300	169,5	40-60	110	125	110	50	15	2	M12	M16/80	450-900	800-1300	3400	12,3	275	132	37	1600	194,5	60-90	150	168	125	60	19	2	M12	M12/90	500-1000	900-1600	3050	16,5	320	152	46																																																																												
300	119,5	30-42	90	102	74	32	10	2	M8	M8/18	60-200	100-300	4800	3,5	39																																																																																																																																																																						
					95		31									500	129,5	35-50	100	112	74	32	10	2	M8	M8/26	80-250	200-500	4550	4,5	80	95	31	800	169,5	40-60	110	125	110	50	15	2	M12	M16/45	260-600	500-900	3400	12,3	275	132	37	1300	169,5	40-60	110	125	110	50	15	2	M12	M16/80	450-900	800-1300	3400	12,3	275	132	37	1600	194,5	60-90	150	168	125	60	19	2	M12	M12/90	500-1000	900-1600	3050	16,5	320	152	46																																																																																														
500	129,5	35-50	100	112	74	32	10	2	M8	M8/26	80-250	200-500	4550	4,5	80																																																																																																																																																																						
					95		31									800	169,5	40-60	110	125	110	50	15	2	M12	M16/45	260-600	500-900	3400	12,3	275	132	37	1300	169,5	40-60	110	125	110	50	15	2	M12	M16/80	450-900	800-1300	3400	12,3	275	132	37	1600	194,5	60-90	150	168	125	60	19	2	M12	M12/90	500-1000	900-1600	3050	16,5	320	152	46																																																																																																																
800	169,5	40-60	110	125	110	50	15	2	M12	M16/45	260-600	500-900	3400	12,3	275																																																																																																																																																																						
					132		37									1300	169,5	40-60	110	125	110	50	15	2	M12	M16/80	450-900	800-1300	3400	12,3	275	132	37	1600	194,5	60-90	150	168	125	60	19	2	M12	M12/90	500-1000	900-1600	3050	16,5	320	152	46																																																																																																																																		
1300	169,5	40-60	110	125	110	50	15	2	M12	M16/80	450-900	800-1300	3400	12,3	275																																																																																																																																																																						
					132		37									1600	194,5	60-90	150	168	125	60	19	2	M12	M12/90	500-1000	900-1600	3050	16,5	320	152	46																																																																																																																																																				
1600	194,5	60-90	150	168	125	60	19	2	M12	M12/90	500-1000	900-1600	3050	16,5	320																																																																																																																																																																						
					152		46																																																																																																																																																																														

- Option: reine Passfederverbindung auch mit Klemmring auch in Edelstahlausführung erhältlich auch als Durchrastkupplung lieferbar
- Temperaturbereich: -30° bis + 130°

- Option: also available with Keyway also available with clamping ring also available in multi-position re-engagement available in stainless steel
- Temperature range: -30° bis + 130°