

# Star Spring Washers for Axial Preloading



20

RINGSPANN<sup>®</sup> Registered Trade Mark of RINGSPANN GmbH, Bad Homburg



# RINGSPANN-Star Spring Washers

## An Important Aid to Better Bearing Location

### Description

RINGSPANN Star Spring Washers are particularly light spring elements with linear or not-linear spring characteristic. They are suitable for application as pressure elements in precision machines, phonographic and film instruments, as pressure springs for taking up free movement, and for reducing noise in ball bearings.

### Service Life

Ball bearings give longer service if the inner and outer rings are pre-loaded axially (figure 1). This fact has been known for a long time, e.g. with internal grinder spindles and has been described and proved by bearing experts<sup>1)</sup>. This axial preloading by RINGSPANN Star Spring Washers eliminates radial play in the ball bearings. This effects a better distribution of the radial load to be transmitted onto the bearing rings and therefore increases the length of service life of the bearing.

<sup>1)</sup> Details in: Dr. R. Kamps „Lager- u. Schmiertechnik, insbesondere von Verbrennungsmaschinen“ (VDI-Verlag)

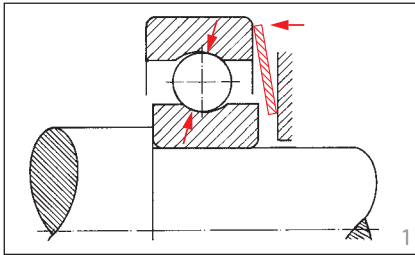

Inner and outer rings are pre-loaded axially

### Silent Running

High speed machines, particularly small electric motors, create special problems for the designer regarding silent running. Extensive trials in this field have shown, that in the main, noise originates in the ball bearings, and that the application of the exact amount of axial pressure suitable for each job reducing noise effectively.

### Protection of Bearings subject to vibration when non-rotating

The spring axial location also eliminates damage as a result of vibration in non-rotating bearings. This type of damage is well known in electric motors for auxiliary drives in ships and vehicles. If the auxiliary drives is stationary, the rotor can vibrate in the bearing, due to the vibration of the ship or vehicle. In these conditions the balls beat in the races of the bearing rings and cause wear. This is why leading manufacturers use only ball bearings, the radial play of which is removed by Star Spring Washers, so preventing any vibration of the rotor. The reason for damage is then completely eliminated.

### Conditions for most favourable effect

The effect of axial pre-loading depends on certain conditions:

- The axial pressure must be applied to the whole outer race.
- The axial pre-loading must be done with a load suitably adapted to the size of the bearing.
- Axial variations and length tolerances within the components of the machine should have only the very slightest effect on the applied spring force.

### Features of the RINGSPANN Star Spring Washers

- Their spring load corresponds with the optimum values of the relevant bearing sizes.
- Because of the large axial variations of the spring it is often possible to achieve the desired effect with a single star spring washer.
- The very large axial movement of the spring guarantees that considerable axial variations and length tolerances can be accommodated without much deviation from the nominal value of the axial force of the star spring washer.

### Notes on installation

Generally it will be found most suitable for the Star Spring Washer to work on the outer ring of the ball bearing. The Star Spring Washer outside diameters given in the following table correspond therefore with the ball bearing outside diameters. The RINGSPANN design with slots and dished shape guarantees even axial pressure on the whole outer race.

If an axial pressure is applied to the shaft in one direction only, the Star Spring Washer must be mounted in such a way that there is no axial pressure on it (figure 5). If the axial pressures vary or are in both directions, a Star Spring Washer has to be mounted both sides of the ball bearings. In this case and in any doubtful cases we will be pleased to submit an installation proposal.

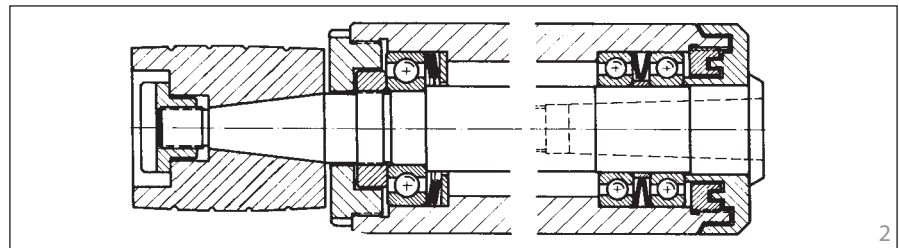

Bearing of an internal grinding spindle

# RINGSPANN-Star Spring Washers

## Specification Table for Standard RINGSPANN Star Spring Washers

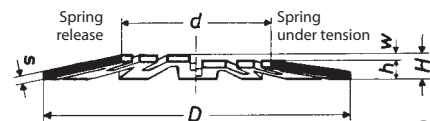

3

For ball bearing					Article number	Star spring Washers			Height released H mm	Height under pressure h mm	Tolerance for h mm	Spring travel w mm	Pressure F N	Spring const. c N/mm
						D mm	d mm	s mm						
				624	1051.012.001	12,7	5,3	0,3	1,1	0,7	± 0,15	0,4	14	35
634	E 3	E 4	E 5	625	1051.015.001	15,7	7,5	0,3	1,1	0,7	± 0,15	0,4	9	23
635				626	1051.018.001	18,7	7,5	0,3	1,4	0,7	± 0,15	0,7	10	14
635				607	1051.018.002	18,7	9,2	0,3	1,2	0,7	± 0,15	0,5	11	22
	E 6				1051.020.001	20,7	10,5	0,3	1,3	0,7	± 0,15	0,6	7	12
627	E 7			608	1051.021.001	21,7	11	0,5	1,6	0,9	± 0,15	0,7	34	49
	E 8			609	1051.023.001	23,7	11	0,5	1,8	1,0	± 0,2	0,8	33	41
629				6000	1051.025.001	25,7	11	0,5	2,0	1,0	± 0,2	1,0	31	31
629				6000	1051.025.002	25,7	13,5	0,5	1,7	1,0	± 0,2	0,7	30	43
16100	E 9	E 10		6001	1051.027.001	27,7	15	0,65	1,9	1,1	± 0,2	0,8	52	65
16101	E 13			6200	1051.029.001	29,7	15	0,66	2,1	1,1	± 0,2	1,0	38	38
	E 11	E 12		6201	1051.031.001	31,7	15	0,65	2,3	1,1	± 0,2	1,2	46	38
16002				6002	1051.031.002	31,7	18	0,65	2,0	1,1	± 0,2	0,9	36	40
16003	E 14	E 15		6003	1051.034.001	34,7	20	0,9	2,4	1,4	± 0,2	1,0	89	89
				6202	1051.036.001	36,7	20	0,9	2,6	1,4	± 0,2	1,2	92	77
	E 16				1051.037.001	37,7	20	0,9	2,7	1,4	± 0,2	1,3	84	65
	E 19	L 17a	Bo 15	6203	1051.039.001	39,7	20	0,9	2,9	1,4	± 0,2	1,5	81	54
	E 19			6203	1051.039.002	39,7	23	0,9	2,6	1,4	± 0,2	1,2	103	86
16004				6004	1051.041.001	41,7	27	0,9	2,4	1,4	± 0,2	1,0	76	76
		EA 17	Bo 17		1051.043.001	43,5	27	0,9	2,6	1,4	± 0,2	1,2	68	57
16005	E 20	L 20	6005	6204	1051.046.001	46,5	27	0,9	2,9	1,4	± 0,2	1,5	74	49
16005			6005	6303	1051.046.002	46,5	30	0,9	2,6	1,4	± 0,2	1,2	72	60
	M 20	L 25	6205	6304	1051.051.001	51,5	35	0,9	2,6	1,4	± 0,2	1,2	61	51
16006		6006			1051.054.001	54,5	35	1,15	3,1	1,7	± 0,25	1,4	98	70
16007	L 30	6007	6206	6305	1051.061.001	61	40	1,15	3,3	1,7	± 0,25	1,6	110	69
16008		6008			1051.067.001	67	45	1,15	3,4	1,7	± 0,25	1,7	90	53
			6207	6306	1051.071.001	71	45	1,15	3,8	1,7	± 0,25	2,1	110	52
16009	6009				1051.074.001	74	50	1,15	3,6	1,7	± 0,25	1,9	130	68
16010	6010	6208	6307	6405	1052.079.001	79	58	1,15	3,3	1,7	± 0,25	1,6	290	—*)
		6209			1052.084.001	84	63	1,15	3,3	1,7	± 0,25	1,6	320	—
16011	6011	6210	6308	6406	1052.089.001	89	63	1,15	3,8	1,7	± 0,25	2,1	290	—
16012	6012				1052.094.001	94	68	1,15	3,8	1,9	± 0,4	1,9	260	—
16013	6013	6211	6309	6407	1052.099.001	99	73	1,15	3,8	1,9	± 0,4	1,9	280	—
16014	6014	6212	6310	6408	1052.109.001	109	78	1,15	4,2	2,0	± 0,4	2,2	180	—
16015	6015				1052.114.001	114	83	1,15	4,2	2,0	± 0,4	2,2	200	—
		6213	6311	6409	1052.119.001	119	88	1,15	4,2	2,0	± 0,4	2,2	270	—
16016	6016	6214			1052.124.001	124	93	1,15	4,2	2,0	± 0,4	2,2	250	—
16017	6017	6215	6312	6410	1052.129.001	129	98	1,15	4,2	2,0	± 0,4	2,2	250	—
16018	6018	6216	6313	6411	1052.139.001	139	98	1,25	5,3	2,3	± 0,5	3,0	330	—
16019	6019				1052.144.001	144	103	1,25	5,3	2,3	± 0,5	3,0	330	—
16020	6020	6217	6314	6412	1052.149.001	149	108	1,25	5,3	2,3	± 0,5	3,0	370	—
16021	6021	6218	6315	6413	1052.158.001	158	118	1,5	5,5	2,5	± 0,5	3,0	410	—
16022	6022	6219	6316		1052.168.001	168	123	1,5	6	2,7	± 0,5	3,3	470	—
16024	6024	6220	6317	6414	1052.178.001	178	133	1,5	6	2,7	± 0,5	3,3	600	—
		6221	6318	6415	1052.188.001	188	138	2	7	3,3	± 0,5	3,7	520	—
16026	6026	6222	6319	6416	1052.198.001	198	143	2	7,5	3,3	± 0,5	4,2	660	—
16028	6028			6417	1052.208.001	208	163	2	6,2	3,0	± 0,5	3,2	1160	—
		6224	6320		1052.213.001	213	168	2	6,4	3,1	± 0,5	3,3	1120	—
16030	6030		6321	6418	1052.223.001	223	183	2	6,1	3,0	± 0,5	3,1	1200	—
		6226			1052.228.001	228	188	2	6,2	3,0	± 0,5	3,2	1160	—
16032	6032		6322		1052.238.001	238	198	2	6,4	3,1	± 0,5	3,3	1120	—
		6228			1052.248.001	248	211	2	6,2	3,0	± 0,5	3,2	1160	—
16034	6034		6324		1052.258.001	258	223	2	6,2	3,0	± 0,5	3,2	1180	—

\*) These and the following sizes have a non-linear spring characteristic.

### Explanation concerning the table

Apart from the listed ball bearing series the Star Spring Washers can also be used for series 32, 33 42, 72 and 73. Pressure P is attained at height h. The spring constant c, i.e. the pressure increase per mm spring travel can only be given up to size 74 x 50 x 1,15. With larger Star Spring Washers the spring

characteristic is not linear but diminishing. With tolerances of the installation height h the pressure F therefore changes even less than with smaller washers. Up to size 129 x 88 x 1,15 the springs can be supplied plated against corrosion.

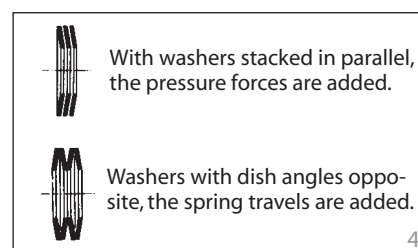

4



# RINGSPANN Star spring washers

## Application Examples

### Pressure and adjusting spring for ball bearing

Silent running is a particular requirement for electric motors. For this purpose a RINGSPANN Star Spring Washer acts to pre-load the outer race of the bearing as illustrated.

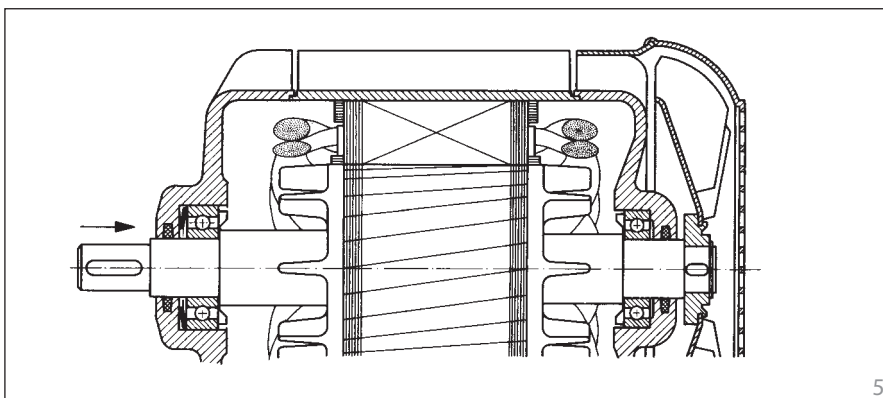

### Friction hub

Here a RINGSPANN Star Spring Washer is used for transmitting low torques. The exact setting of the pressure force is effected by the intermediate discs arranged between the star spring washer and the circlip.

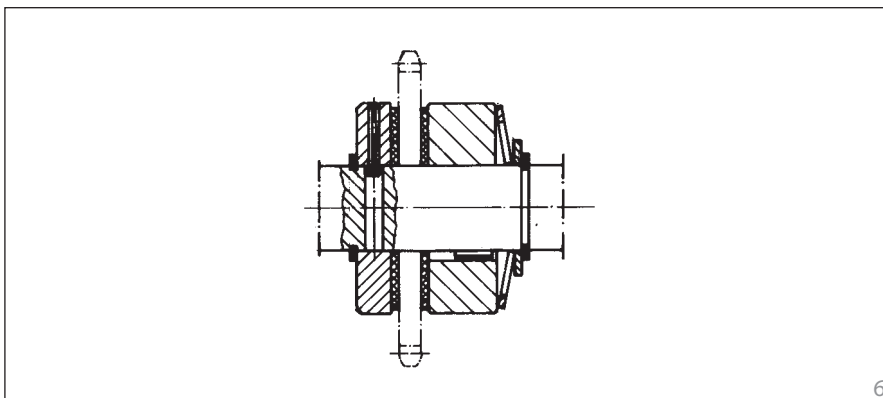

### RINGSPANN Star Spring Washers for accommodating length tolerances

As shown in this example the RINGSPANN Star Spring Washer fitted between output shaft and NILOS sealing ring makes it possible to accommodate wide axial tolerances.

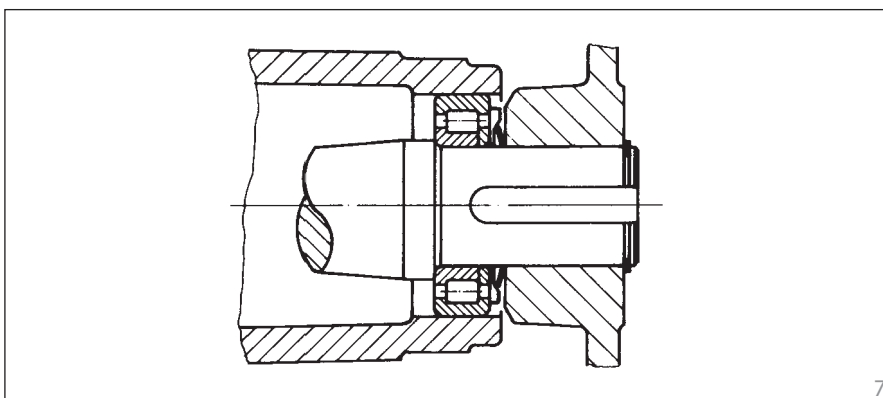

### Locating of guide discs

This example shows guide discs being pressed against a freewheel wedgepiece set, with the RINGSPANN Star Spring Washers being used as a simple and cost effective method of holding the guide discs in position.

In this case the Star Spring Washer takes on a dual function of circlip and pressure disc.

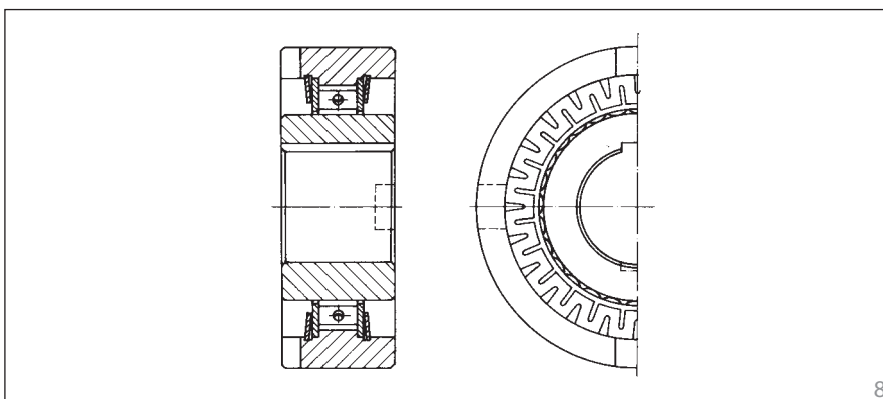

**RINGSPANN GmbH**

Schaberweg 30-34  
61348 Bad Homburg

Telefon +49 6172 275-0  
Telefax +49 6172 275-275

www.ringspann.com  
mailbox@ringspann.com