

Gasdruckfedern | Gas springs

Bestell-Beispiel | Order-Example

Bestellbeispiel | Order Example **A1** **A1** **-** **4** **0** **200** **484** **001*** **500N**

A1	A1	-	4	0	200	484	001*	500N	
Anschlußteile Kolbenstange connecting parts piston rod	Anschlußteile Zylinder connecting parts cylinder	Bauart model	Ausschubgeschwindigkeit/Dämpfung push-out speed/damping	Durchmesser Kolbenstange/ Zylinder diameter piston rod/cylinder	Hub stroke	Einbaulänge 1** extended length 1**	Index Nummer index number	Ausschubkraft extension-force	
					Øx/Øy (mm)	A (mm)	mind. min. EL2 (mm)	F1 (N)	Progression progression
siehe Seite 46 Anschlußteile <i>see page 46 connecting parts</i>	siehe Seite 46 Anschlußteile <i>see page 46 connecting parts</i>	- Normalausführung <i>standard</i> A nach Kundenzeichnung <i>accord. to your drawing</i> B nach eigener Zeichnung <i>according to our drawing</i> C mit Abstreifer <i>with scraper</i> D mit Überrohr (-40°C bis 60°C) <i>with covertube (-40°C to 60°C)</i> E mit neutralen Etiketten <i>with neutral labels</i> F mit Ventil im Zylinder-Endstück <i>with valve inside the cylinder</i> H mit Spezialdichtungen für Temperaturen bis 200° C <i>with special seals for temperatures up to 200° C</i> N nichtrostende Ausführung aus Material 1.4404 <i>stainless steel version in 1.4404</i> R mit erhöhter Reibung <i>with increased friction</i> S mit arretierbarem Schutzrohr (ab 150 mm Hub, bis 160°C) <i>with lockable cover tube (above 150 mm stroke, up to 160° C)</i> T mit Trennkolben <i>with floating piston</i>	0 schnell, keine Enddämpfung <i>fast, no end damping</i> 1 schnell, normale Enddämpfung <i>fast, normal end damping</i> 2 schnell, starke Enddämpfung <i>fast, increased end damping</i> 3 normal, keine Enddämpfung <i>normal, no end damping</i> 4 normal, normale Enddämpfung <i>normal, normal end damping</i> 5 normal, starke Enddämpfung <i>normal, increased end damping</i> 6 langsam, keine Enddämpfung <i>slow, no end damping</i> 7 langsam, normale Enddämpfung <i>slow, normal end damping</i> 8 langsam, starke Enddämpfung <i>slow, increased end damping</i> 9 Sonstige Varianten <i>other variations</i>	K = 3/8 G = 4/12 6 = 6/15 C = 6/19 D = 6/22 0 = 8/19 1 = 8/22 E = 8/28 2 = 10/22 3 = 10/28 4 = 12/28 5 = 14/28 N = 16/28 A = 10/40 F = 12/40 B = 14/40 7 = 20/40 M = 30/70	10-120 10-150 10-150 10-150 10-150 10-300 10-300 10-300 20-800 20-800 20-1000 20-1000 20-1000 20-1000 20-1000 20-1000 20-1000 100-800	2x Hub <i>stroke</i> +20 2x Hub <i>stroke</i> +30 2x Hub <i>stroke</i> +30 2x Hub <i>stroke</i> +42 2x Hub <i>stroke</i> +43 2x Hub <i>stroke</i> +48 2x Hub <i>stroke</i> +48 2x Hub <i>stroke</i> +60 2x Hub <i>stroke</i> +47 2x Hub <i>stroke</i> +60 2x Hub <i>stroke</i> +60 2x Hub <i>stroke</i> +60 2x Hub <i>stroke</i> +60 2x Hub <i>stroke</i> +70 2x Hub <i>stroke</i> +70 2x Hub <i>stroke</i> +70 2x Hub <i>stroke</i> +90 2x Hub <i>stroke</i> +120	*Durch die Indexnummer – nur für Ihre Nachbestellung erforderlich – können wir einmal gefertigte Produkte exakt reproduzieren. Sie erhalten den Indexcode mit der Auftragsbestätigung / Rechnung. *With the index no. – only necessary for repeating orders – we can reproduce exactly the same gas spring which has already been produced. You will receive the index no. with the order confirmation / invoice.	7-110 ca. 28 % 7-200 ca. 21 % 10-400 ca. 27 % 10-400 ca. 16 % 10-400 ca. 11 % 30-700 ca. 33 % 30-700 ca. 22 % 30-700 ca. 13 % 50-1300 ca. 39 % 50-1300 ca. 21 % 100-1700 ca. 33 % 150-2600 ca. 52 % 200-3200 ca. 85 % 50-1300 ca. 8 % 100-1700 ca. 13 % 150-2600 ca. 18 % 200-5000 ca. 45 % 1000-12000 ca. 25 %	

Optionen | Options

Durchmesser size Øx/Øy (mm)	Abstreifer scraper EL 2 +10 mm	Überrohr cover tube EL 2 +10 mm	Ventil valve	Hochtemperatur Dichtung high-temp. seals	Kältebest. Dichtung low-temp. seals	Nirosta (S. 36) stainless steel (see page 36)	Reibung friction EL 2 +10 mm	Arretierb. Schutzrohr lockable cover tube EL 2 +26 mm	Trennkolben floating piston
3/8									
4/12									
6/15	• (EL2 +5mm)		• +2mm	•	•	•	•		•
6/19	•	Kunststoff <i>plastic</i>	•	•	•	•	•		•
6/22	•	Kunststoff <i>plastic</i>	•	•	•	•	•		•
8/19	•	Kunstst.+Stahl <i>plastic+steel</i>	•	•	•	•	•		•
8/22	•	Kunststoff <i>plastic</i>	•	•	•	•	•		•
8/28	•	Kunststoff <i>plastic</i>	•	•	•	•	•		•
10/22	•	Kunststoff <i>plastic</i>	•	•	•	•	•	•	•
10/28	•	Kunststoff <i>plastic</i>	•	•	•	•	•		•
12/28	•	Kunststoff <i>plastic</i>	•	•	•	•	•		•
14/28	•	Kunststoff <i>plastic</i>	•	•	•	•	•		•
16/28	•	Kunststoff <i>plastic</i>	•	•	•	•	•		•
10/40	•	Stahl <i>steel</i>	•	•	•	•	•		•
12/40	•	Stahl <i>steel</i>	•	•	•	•	•		•
14/40	•	Stahl <i>steel</i>	•	•	•	•	•		•
20/40	•		•	•	•	•	•		•
30/70	standard		standard						•

EL1	EL2
<p>**Achtung **Attention</p> <p>Berechnung der Einbaulänge erfolgt mit ausgefahrener Kolbenstange. Die Länge der gewünschten Anschlußteile zur Ermittlung der Gesamteinbaulänge hinzurechnen. <i>The total length is calculated when the piston rod is extended. Please add the length of the connecting parts in order to find out the total length.</i></p>	<p>Festlegung einer Ausführung - Beispiel</p> <p>Wir empfehlen die Festlegung der Baureihe anhand der notwendigen Kraft und der vorgesehenen Hub-/ Einbaulänge. Im Bestellbeispiel wurde aufgrund von 500N und 200 mm Hub die Baureihe 8/19 mm festgelegt. Die mögliche Einbaulänge berechnet sich wie folgt:</p> <p>2 x 200 mm (Hub) + 48 mm = 448 mm (EL2) + Anschlussteil Kolbenstange A1 = 20 mm (Seite 46) + Anschlussteil Zylinder A1 = 16 mm (Seite 46) Mindest-Einbaulänge = 484 mm (EL1)</p> <p>Aufrundungen auf übliche Längen, z.B. 485 / 490 / 500 oder auf vorhandene Befestigungspunkte, z.B. 550 sind jeweils aus lagerhaltigen Bauteilen kurzfristig lieferbar.</p>
<p>Einbaulänge EL2 = ohne Gelenkaugen/ohne Gewindelänge gemessen <i>length EL2 = measured without hinge eyes and threads</i></p>	<p>Determination of a gas spring type - Example</p> <p>We recommend the determination of a gas spring type by the required force and the intended stroke-/ extended length. In the order example the 8/19 type was determined due to 500N and 200 mm stroke. The possible extended length is calculated as follows:</p> <p>2 x 200 mm (stroke) + 48 mm = 448 mm (EL2) + connecting part piston rod A1 = 20 mm (page 46) + connecting part cylinder A1 = 16 mm (page 46) Minimum extended length = 484 mm (EL1)</p> <p>Rounding up on common lengths, e.g. 485 / 490 / 500 or on existing mounting points, e.g. 550 are each available in a short time due to stocking components.</p>

Edelstahl Gasfedern

Stainless steel gas springs

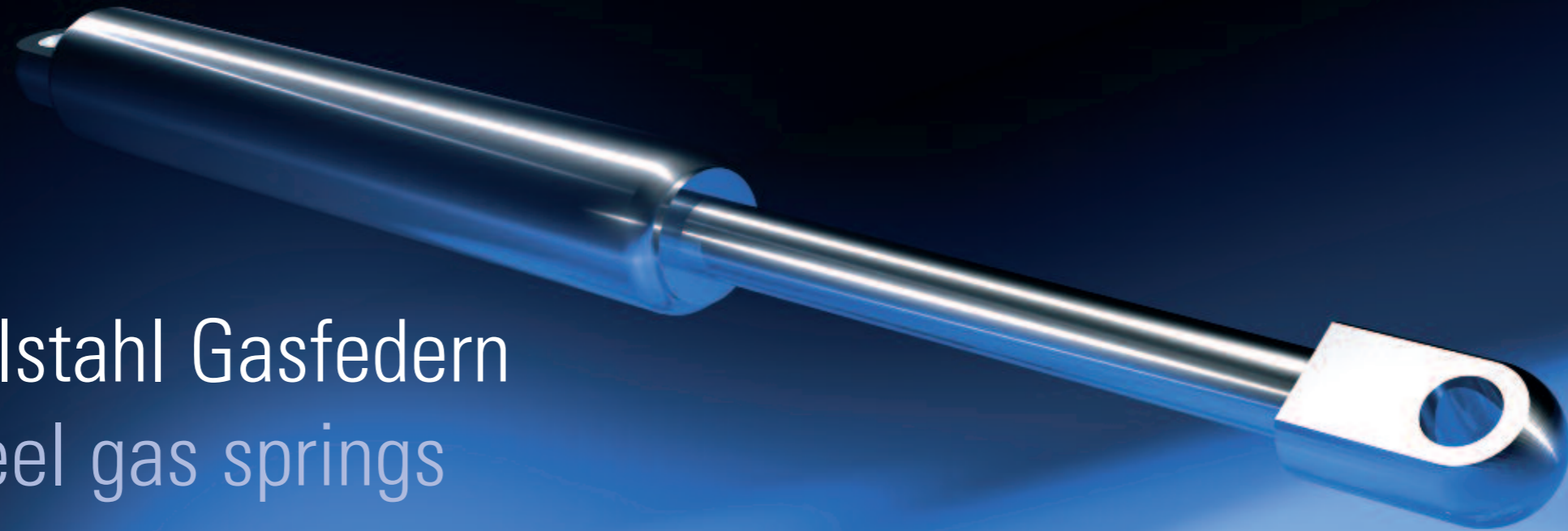

Medizin- und Reha-technik
Medical & rehabilitation equipment



Outdoor Möbel
Outdoor Furniture



Freizeit
Leisure



Maschinenbau
Machinery



Maritim Industrie
Maritim Industry



Sonstiges
Others

Standard-Gasfedern gibt es in vielen Längen, Stärken und Variationen und auch aus hoch korrosionsbeständigem Material.

Gas springs are available in a number of different lengths, forces and variations. They are also available in highly corrosion-resisting material.

Bansbach easylift fertigt Edelstahl-Gasfedern aus hochwertigem Niro-Material (V4A, AISI Nr. 316L). Sie sind damit nicht nur wasserresistent, sondern auch in den Bereichen Nahrungsmittel, Chemie und Seewasser einsetzbar. Einige Baureihen der Standard-Gasfeder sind auf Wunsch auch in V2A, AISI Nr. 304 lieferbar. Bitte Niro-Klasse der lieferbaren Anschlussstücke beachten. Alle Gasfedern dieser Baureihe sind mit Ventil ausgerüstet (Ausnahme: P-Modell, Zugfeder mit Dämpfung).

We mostly use high-quality stainless steel material (V4A i.e. AISI-no. 316L) for the production of the stainless steel gas springs. They are not only resistant to water but are commonly found in food, chemical and salt water applications. If requested, some sizes of the standard gas spring are available in V2A (AISI 304), too. Please see our connecting parts available in stainless. All gas springs in these high-quality product groups are made with a valve, with the exception of P-models and traction springs with damping.

Gasdruckfedern
Baureihen, Daten, Maßzeichnungen sowie Bestellbeispiele weitgehend wie Standard-Gasfedern (siehe Seite 8).

Blockierfedern
Baureihen, Daten, Maßzeichnungen sowie Bestellbeispiele weitgehend wie Standard-Blockierfedern (siehe Seite 12). (Bei P-Modell: F1=max. 300 N)

Gaszugfedern, auch blockierbar
Baureihen, Daten, Maßzeichnungen sowie Bestellbeispiele weitgehend wie Standard-Gaszugfedern (siehe Seite 34) (Mit Dämpfung: F1=max. 300 N).

Dämpfer
Baureihen, Daten, Maßzeichnungen sowie Bestellbeispiele weitgehend wie Standard-Dämpfer (siehe Seite 40).

Gas springs
Sizes, data, drawings as well as order examples are almost the same as for our standard gas springs (see page 8).

Lockable gas springs
Sizes, data, drawings as well as order examples are almost the same as for our standard lockable gas springs (see page 12). (For P-model: F1= max. 300 N)

Gas traction springs, also lockable
Sizes, data, drawings as well as order examples are almost the same as for our standard gas traction springs (see page 34). (With damping: F1= max. 300 N)

Damper
Sizes, data, drawings as well as order examples are almost the same as for our standard damper (see page 40).



Edelstahl Anschlusssteile | Stainless steel connecting parts

Gelenkaugen Kolbenstange | Piston rod hinge eyes

Material 1.4404 / AISI 316L								geeignet für: suitable for:		
Code	SW	Ø	L ₁	L ₃	Ø ₂	d ₁	Gewinde thread	Gasdruckfedern Gas springs	Block. Gasfedern Lockable gas springs	Gaszugfedern Gas traction springs
D1	3	6,2	16	9	11	6,0	M5	●		
A1	10	8,2	20	20	16	8,0 - 10,0	M8	●		●
M2	10	10,2	20	20	16	8,0 - 10,0	M8	●		●
B1	12	8,2	25	12	19	10,0 - 14,0	M10	●		●
K2	12	8,2	20	20	19	10,0 - 14,0	M10	●		●
C1	14	14,2	40	20	20	14,0 - 20,0	M14*1,5	●		●

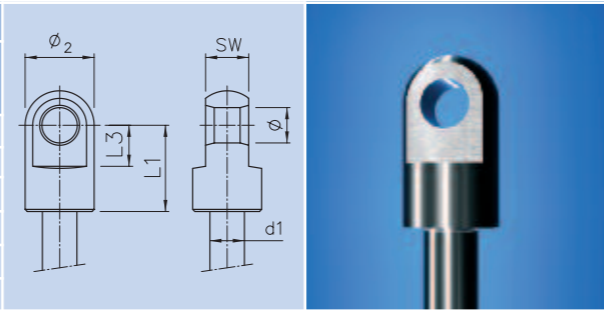

Gelenkaugen Zylinder | Hinge eyes cylinder

Material 1.4404 / AISI 316L								geeignet für: suitable for:		
Code	SW	Ø	L ₂	L ₄	Ø ₂	d ₂	Gewinde thread	Gasdruckfedern Gas springs	Block. Gasfedern Lockable gas springs	Gaszugfedern Gas traction springs
D1	3	6,2	16	9	11	15,0	M5	●		
A1	10	8,2	20	20	16	19,0 - 22,0	M8	●	●	●
M2	10	10,2	20	20	16	19,0 - 22,0	M8	●	●	●
B1	12	8,2	25	12	19	28,0 - 40,0	M10	●	●	●
K2	12	8,2	20	20	19	28,0	M10	●	●	●
C1	14	14,2	40	20	20	40,0	M14*1,5	●	●	●

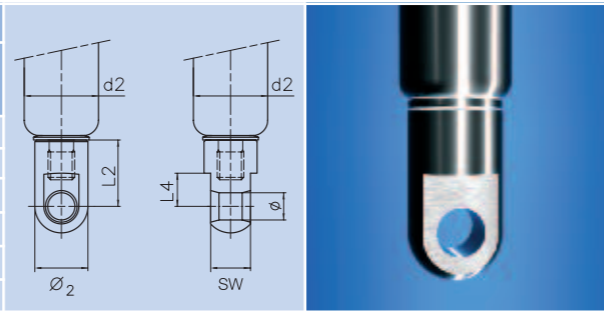

Gewinde Kolbenstange | Threads piston rod side

Material 1.4404 / AISI 316L				geeignet für: suitable for:		
Code	M ₁	L ₁	d ₁	Gasdruckfedern Gas springs	Blockierbare Gasfedern Lockable gas springs	Gaszugfedern Gas traction springs
V0	M5	5	6,0	●		●
B0	M8	9	8	●		●
H0	M8	9	10,0	●		●
D0	M10	9	10,0-14,0	●		●
Z0	MF14*1,5	15	20,0	●		●

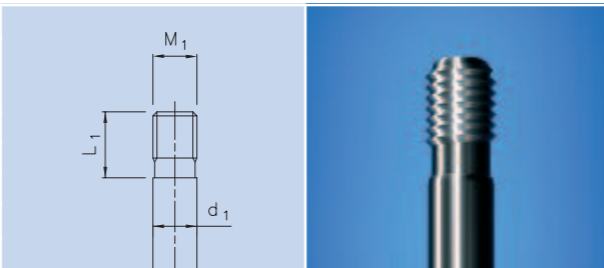

Gewinde Zylinder | Threads cylinder side

Material 1.4404 / AISI 316L				geeignet für: suitable for:		
Code	M ₂	L ₂	d ₂	Gasdruckfedern Gas springs	Blockierbare Gasfedern Lockable gas springs	Gaszugfedern Gas traction springs
V0	M5	5	15,0	●		●
Z0	MF14*1,5	15	40,0	●	●	●
M0	M10	13	28,0-40,0	●	●	●
N0	M8	8	19,0-28,0	●	●	●

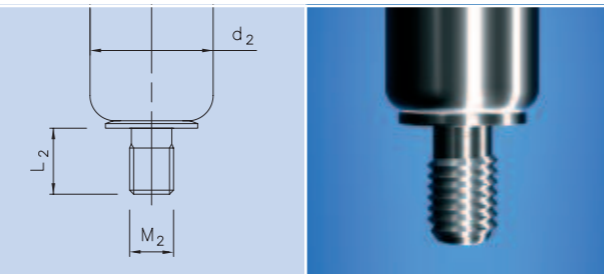

Winkelgelenke | Elbow joints

Material 1.4305 / AISI 303						
Code	AØ	Lmm	b*cmm	d*emm	fmm	Mutter/nut
D3	10	19	M8x9,5	M8x13	12	nein/no
A3	13	30	M8x14,5	M8x16,5	13	ja/yes
A4	16	35	M10x15,5	M10x20	16	ja/yes
B4	19	45	M14*1,5 x 20	M14*1,5 x 28	20	ja/yes

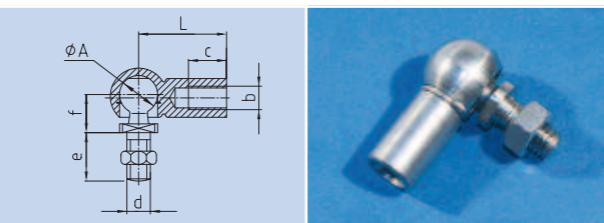

Gabelköpfe | Clevises

Material 1.4305 / AISI 303							
Code	Ød, mm	gmm	Amm	bmm	L ₁ mm	L ₂ mm	Ød ₂ mm
A5	8	16	16	8	42	32	M8
B9	10	20	20	10	52	40	M10

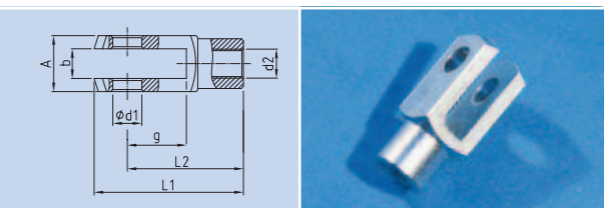

Gelenkköpfe | Hinge heads

Material 1.4057										
Code		a	b1	d1	d2	d3	d6	h	L	L3
A7	GEKA7M8NI	8°	8	8	16	M8	24	36	16	12
A8	GEKA8M10NI	6°	9	10	19	M10	28	43	20	13

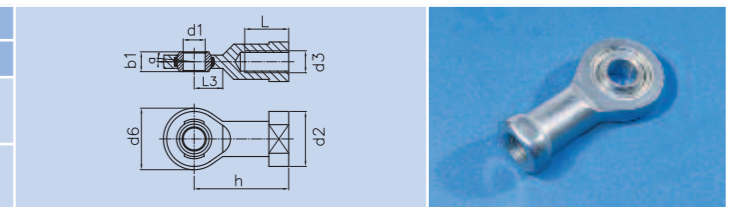

Kugelpfannen | Ball sockets

Material 1.4305 / AISI 303			
Code	A	L	b*c
F3	10	19	M8*10
P3	13	30	M8*14

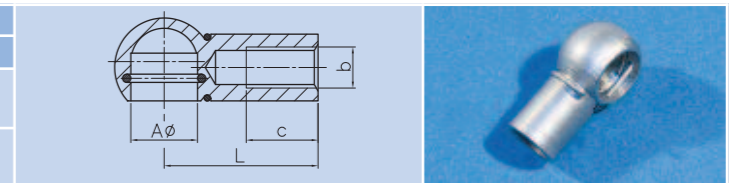

Kugelbolzen | Bolts

Material 1.4305 / AISI 303			
Best.-Nr. Order No.	A	d*e mm	f mm
KB10M8*13NI	10	M8*13	12
KB13M8*16.5NI	13	M8*16.5	13

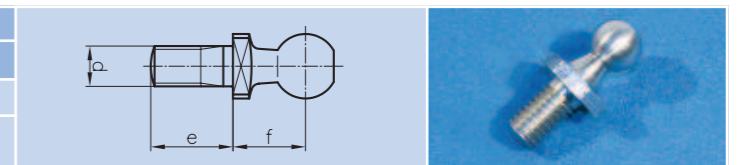

Bolzen für A5 | Bolt for A5

Material 1.4305 / AISI 303		
Code	Best.-Nr. Order No.	Maße gemäß Zeichnung / measures see drawing
M5	B0M5NI	Maße gemäß Zeichnung / measures see drawing

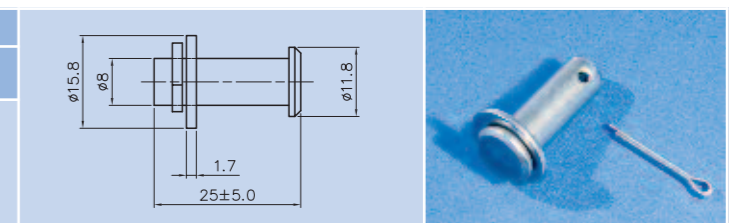

Beschläge | Brackets

Code	Material 1.4301 / AISI 304
900BA1NISR	

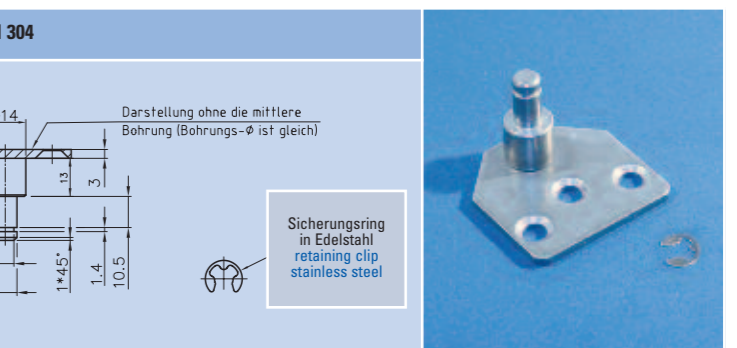

Code	Material 1.4301 / AISI 304
900BA2NISR	

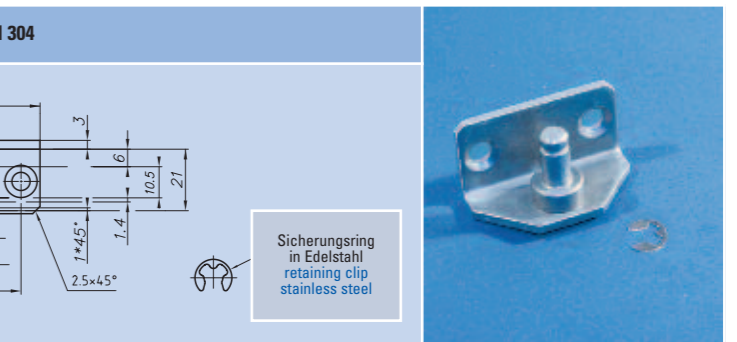

Code	Material 1.4301 / AISI 304
900BA6NIBO	

